



Extractores helicoidales

Este modelo es el resultado de procesos productivos de tecnología y control de calidad avanzado.

Álabes de características especiales y diseño eficiente con 22 configuraciones de hélice de motor.

CARACTERÍSTICAS:

- Hélices aerodinámicas y eficientes.
- Embocadura embutida en todos los tamaños con venturi prolongado para reducción de turbulencias.
- Diseño especial de soporte y base motor de gran resistencia, que facilita el mantenimiento.
- Rodamientos a bolas de uso industrial.
- Acabado de pintura en polvo poliéster electrostático.
- Eje en acero calculado con diámetros que superan los parámetros de carga.
- Motores trifásicos totalmente cerrados, con ventilación forzada.

APLICACIONES:

- Extracción o ventilación de uso industrial.
- Ideal para mover grandes volúmenes de aire.
- Para ambientes donde el nivel sonoro sea un factor importante.

RANGOS DE FABRICACIÓN:

Modelos 800 (31 ") a 1250 (49")

Hélices de 6 álabes con diseño aerodinámico fabricado en acero al carbón y unido a un disco estrella, embutido de fijación a flecha.

Modelos 1500 (59") y 1800 (71 ")

Hélices de gran robustez, con 6 álabes para el modelo 1800 y 5 palas para el modelo 1500. Fabricadas en acero al carbón, unidas al casquillo por un cartabón en placa de acero de gran resistencia y asegurada con tornillería especial.

Aplicaciones especiales:

- Atmósferas corrosivas: acabado pintura epóxica, altos sólidos o recubrimientos fenólicos.
- Motores ATEX.



ALMACENES Y
BODEGAS



NAVES
INDUSTRIALES



INVERNADEROS



ESTACIONAMIENTOS



POLIDEPORTIVOS



INDUSTRIA
AUTOMOTRIZ

(01) 461-2277

ventas@friotemp.com.pe



WWW.FRIOTEMP.COM.PE

Friotemp
AIRE ACONDICIONADO Y VENTILACIÓN

DIMENSIONES

MODELO	A	B	C	D	E	ØF
HGB-T 800	1008	835	800	468	90	15.9
HGB-T 1000	1174	973	1013	548	98	15.9
HGB-T 1250	1455	1255	1261	555	103	15.9
HGT 1500	1769	1582	1504	694	170	15.9
HGT 1800	2032	1724	1850	900	193	22.2

*Dimensiones mm.

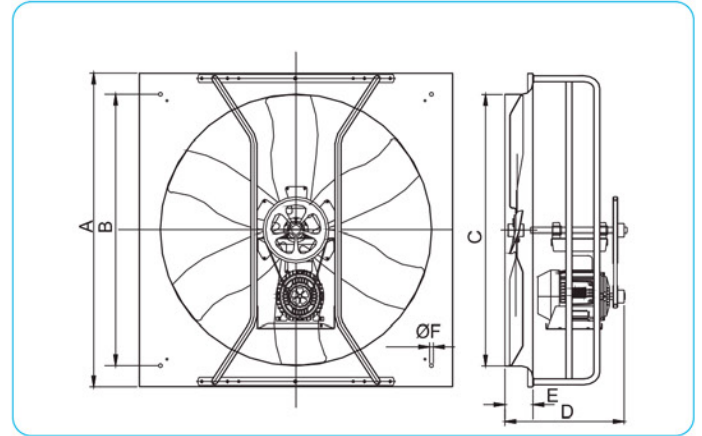

CARACTERÍSTICAS TÉCNICAS

Modelo	Velocidad RPM	Potencia HP	Tensión Volts	Intensidad A	Caudal a descarga libre m ³ /hr / CFM	Presión sonora dB(A)*	Peso apróx. Kg
HGB-800-1/2	530	1/2	127/220	8.0/3.8	12,146 / 7,145	58	41
HGT-800-1/2	530	1/2	220/440	1.9/1.0	12,146 / 7,145	58	41
HGT-800-3/4	700	3/4	220/440	3.0/1.5	16,200 / 9,529	66	41
HGB-800-1	800	1	127/220	17.5/7.5	18,340 / 10,788	69	41
HGT-800-1	800	1	208-230/460	3.0/1.5	18,340 / 10,788	69	41
HGT-1000-3/4	550	3/4	220/440	3.0/1.5	24,666 / 14,509	67	48
HGB-1000-1	610	1	127/220	17.5/7.5	27,630 / 16,253	69	48
HGT-1000-1	610	1	208-230/460	3.0/1.5	27,630 / 16,253	69	48
HGT-1000-1 1/2	700	1 1/2	208-230/460	4.2/2.1	31,663 / 18,625	72	48
HGB-1250-1	450	1	127/220	17.5/7.5	32,300 / 19,000	68	61
HGT-1250-1	450	1	208-230/460	3.0/1.5	32,300 / 19,000	68	61
HGT-1250-1 1/2	500	1 1/2	208-230/460	4.2/2.1	35,833 / 21,078	70	61
HGB-1250-2	540	2	127/220	29.0/13.5	38,900 / 22,882	72	65
HGT-1250-2	540	2	208-230/460	6.2/3.1	38,900 / 22,882	72	65
HGT-1250-3	610	3	208-230/460	7.8/3.9	43,750 / 25,735	74	76
HGT-1500-3	550	3	208-230/460	11.0/5.5	59,400 / 34,941	76	144
HGT-1500-5	550	5	208-230/460	15.2/7.6	74,630 / 43,900	79	148
HGT-1500-7 1/2	550	7 1/2	208-230/460	20.2/10.1	85,989 / 50,581	84	164
HGT-1500-10	550	10	208-230/460	26.8/13.4	92,582 / 54,460	87	172
HGT-1800- 7 1/2	440	7 1/2	208-230/460	20.2/10.1	104,445 / 61,438	81	311
HGT-1800-10	440	10	208-230/460	26.8/13.4	118,340 / 69,612	85	318
HGT-1800-15	440	15	208-230/46	35.8/17.9	136,875 / 80,515	89	358

*Nivel sonoro medido de acuerdo a normas AMCA 300/05 y 301/05

(01) 461-2277

ventas@friotemp.com.pe



WWW.FRIOTEMP.COM.PE

Friotemp
AIRE ACONDICIONADO Y VENTILACIÓN

CARACTERÍSTICAS ACÚSTICAS

Modelo	Frecuencia Hz.								LwA	dB(A)
	63 Hz	125 Hz	250 Hz	500 Hz	1000 Hz	2000 Hz	4000 Hz	8000 Hz		
HGB-T 800-1/2	58	61	68	66	65	62	56	52	69	58
HGT-800-3/4	66	69	76	74	73	70	64	60	77	66
HGB-T 800-1	70	73	80	77	76	73	67	63	81	69
HGT-1000-3/4	66	70	77	75	74	71	65	61	78	67
HGB-T 1000-1	68	72	79	77	76	73	67	62	80	69
HGT 1000-1 1/2	71	75	82	80	79	76	70	66	83	72
HGB-T 1250-1	67	71	78	76	75	72	66	63	79	68
HGT-1250-1 1/2	69	73	80	78	77	74	68	65	81	70
HGB-T 1250-2	71	75	82	80	79	76	70	67	83	72
HGT-1250-3	73	77	84	82	81	78	72	69	85	74
HGT-1500-3	75	79	86	84	83	80	74	71	87	76
HGT-1500-5	78	82	89	87	86	83	77	74	90	79
HGT-1500-7 1/2	83	87	94	92	91	88	82	79	95	84
HGT-1500-10	85	90	97	96	94	91	85	82	99	87
HGT-1800-7 1/2	79	84	91	90	88	85	79	76	93	81
HGT-1800-10	84	89	95	94	92	89	83	80	97	85
HGT-1800-15	86	91	97	96	94	91	95	82	100	89

CURVAS CARACTERÍSTICAS

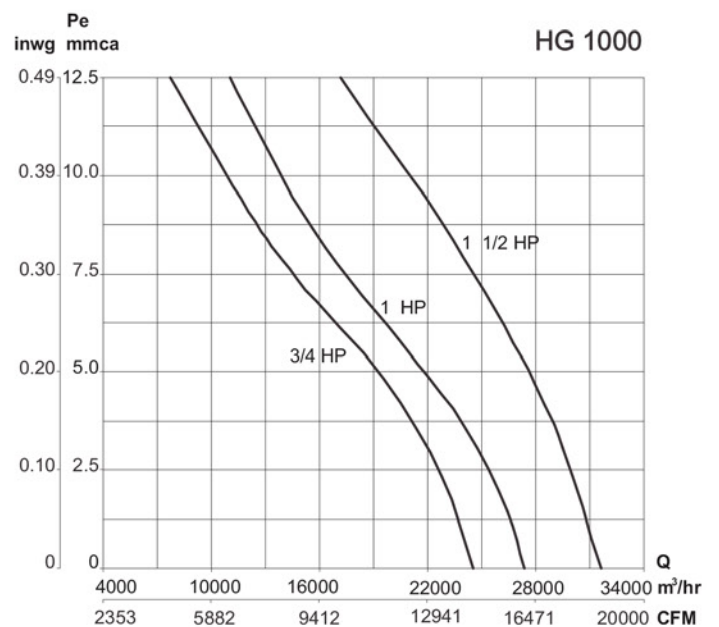
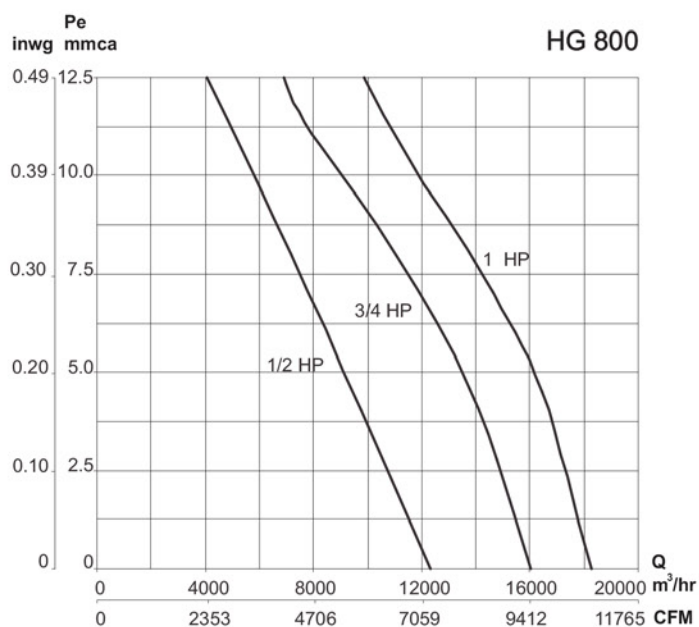

(01) 461-2277

ventas@friotemp.com.pe



WWW.FRIOTEMP.COM.PE

Friotemp
AIRE ACONDICIONADO Y VENTILACIÓN

CURVAS CARACTERÍSTICAS

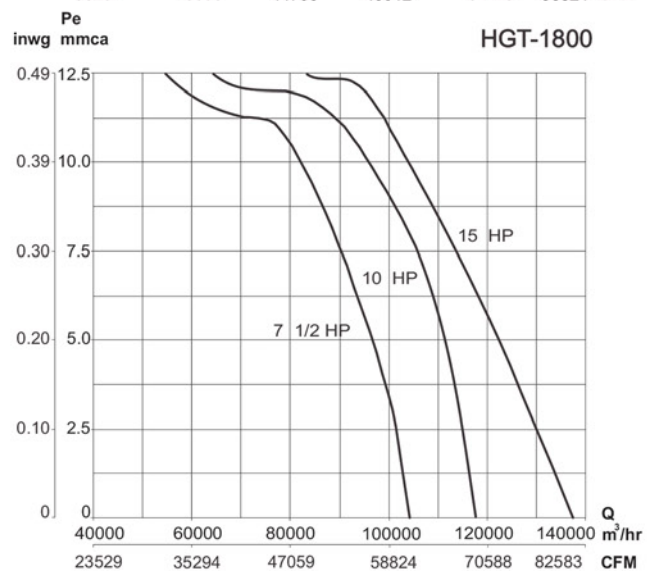
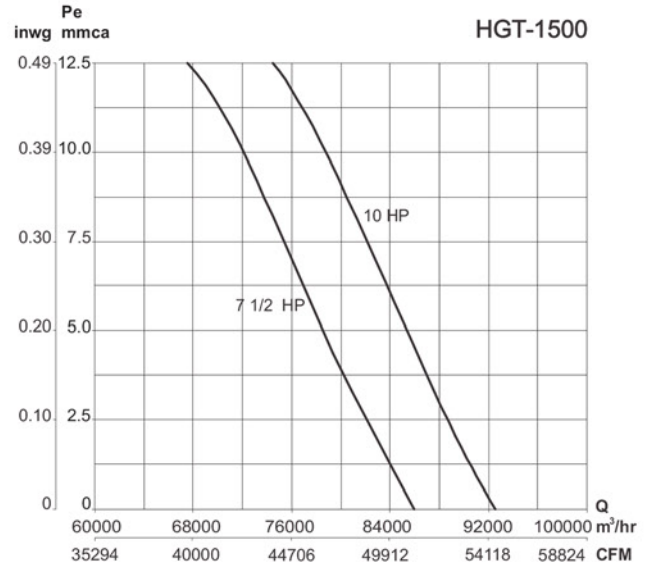
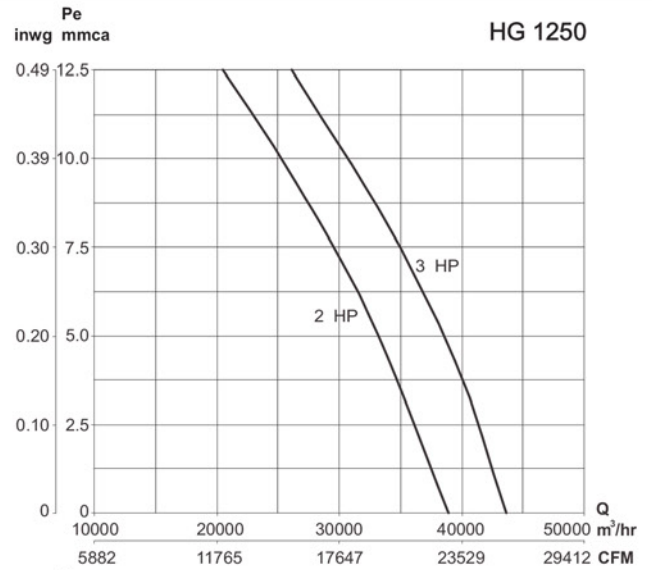
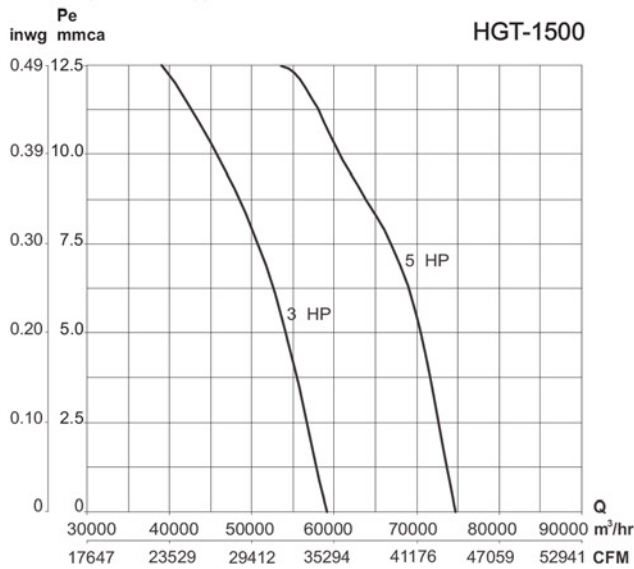
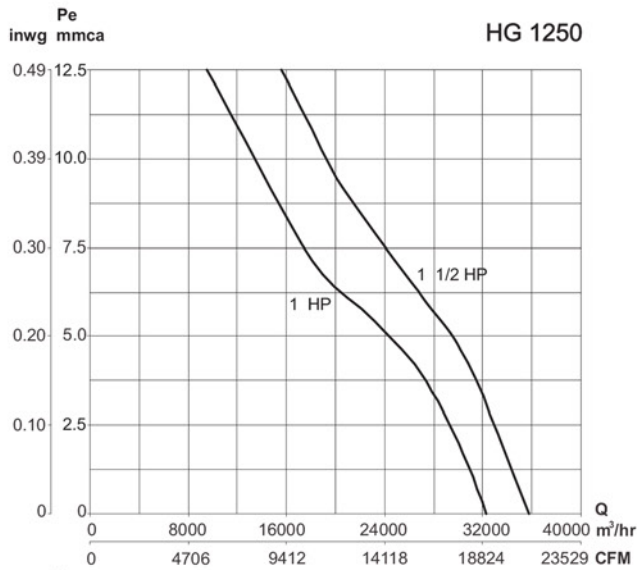

ACCESORIOS:

- Cubierta intemperie a 45°.
- Persiana de gravedad.
- Unión persiana.
- Malla de protección.

(01) 461-2277

ventas@friotemp.com.pe



WWW.FRIOTEMP.COM.PE

Friotemp
AIRE ACONDICIONADO Y VENTILACIÓN